

Street Art Display Stand

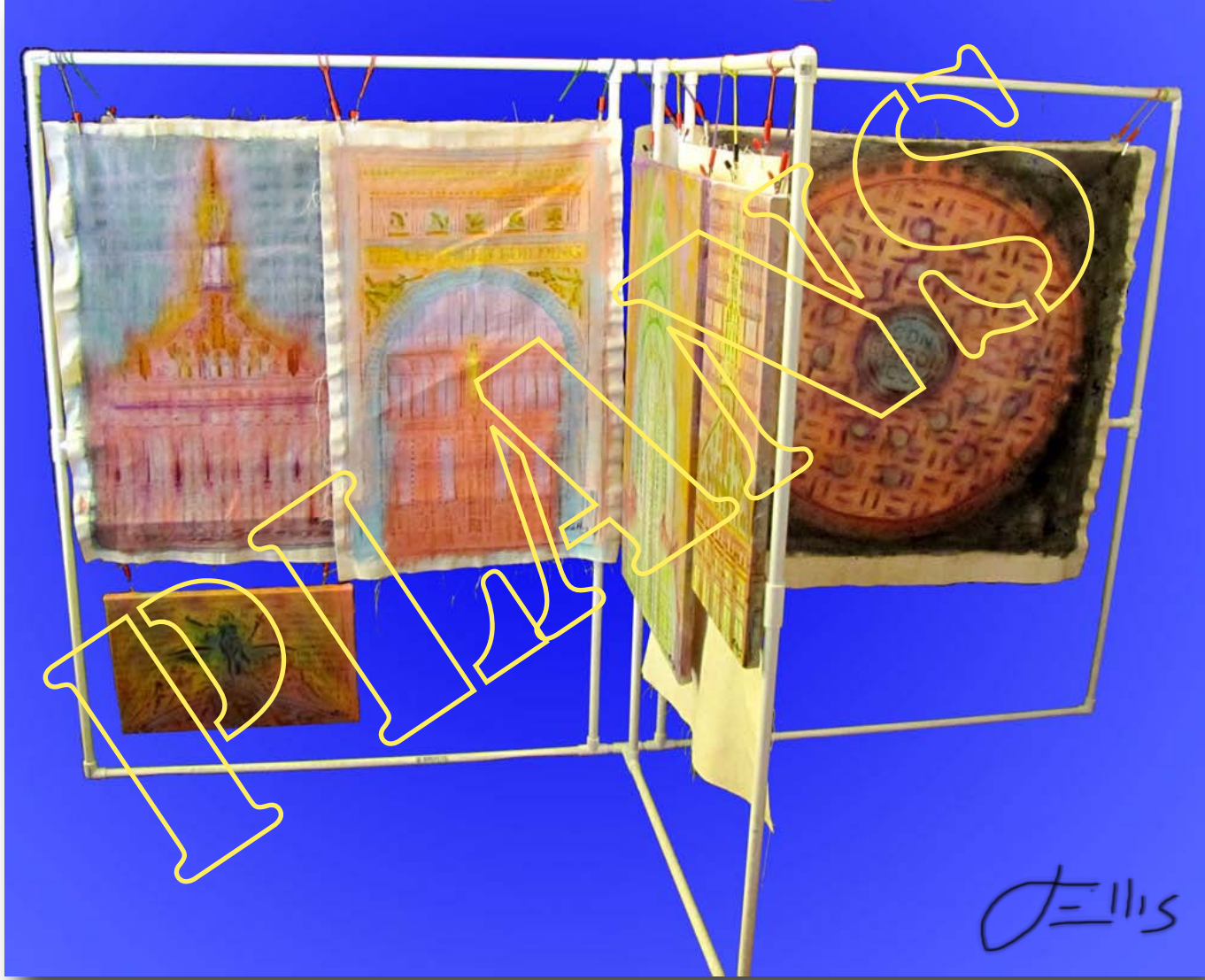

There are a few rules and regulations having to do with selling your art on the streets.

In New York City we are incredibly fortunate to have **Mr. Robert Lederman** as an advocate and I thank him for his work and his dedication. It was through his blog that I found the dimensions that we as artists selling our work on the street must work within. We are entitled to a display 8 feet long, 5 feet high and 3 feet deep. This is just fine for people selling stacks of reproductions or photos or sculpture since all they need to do is set out an 8 foot table and open for business. For the rest of us who are selling canvases that really need to be hung in order to show them at their best we have been constrained to all manner of contraption and clogged together bits and pieces of wire mesh, ladders, bits of board and whatever - to stay within the established rules and show off our work. But that's why you are now in possession of these plans.



You will be building this.

What you will be building is easy and quick to build. It is also cheap since including the cost of the plans you will be spending less than \$20.00.

I have done my best to make everything included here as clear as possible and I encourage anyone who finds something that is not understandable (or a typo) to write to me at jon@ltbprod.com. I will make any necessary changes and I will then send a copy of the revised edition to everyone who has purchased from me. In your email if you are in need of immediate assistance just request a call and I will call you and guide you through whatever has you stumped. Frankly I say all this with the firm belief that anyone can figure this out because it's simple. On the other hand I do know that sometimes I personally tend to complicate the simple and i want to leave that door open for others who do the same sort of thing.

The following pages contain all the information you will need to build your display stand. There are extra images of neary every aspect. There are reminders of key aspects on pages that relay on information contained on previous pages, and there is as much information as possible on how to do this with as little effort as possible.

Ultimately this should not be a task that annoys you but rather one that will give you the same sort of satisfaction that putting together LEGO's or Sticks and Wheels, or Lincoln Logs or Erector Set models. It should make you happy, and at the same time you will have constructed something that is **portable**, **collapsible**, and **strong**. It will enable you to display your work as it was meant to be displayed.

I wish you all the very best, that you ultimately reach your artistic dreams, and that this simple display stand helps you to do just that.

Make art,

A handwritten signature in black ink that reads "J=llis". The signature is stylized and cursive.

Parts and Tools List

I used 1/2 inch PVC pipe but if you need a stronger (slightly heavier) unit just go for a larger size... (well - duh:)

Expect this project to take between one and two hours - total!

1.50
4.20
7.21
\$12.91 + tax = total cost

a. 6 - 90 degree elbows = .25@ = **\$1.50**

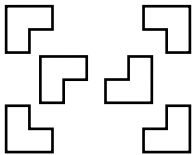

b. 14 - T's = .30@ = **\$4.20**

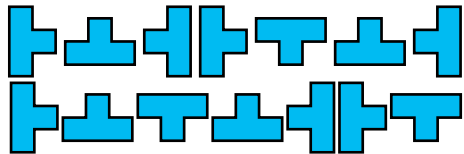

c. 12 - 28" upright pieces

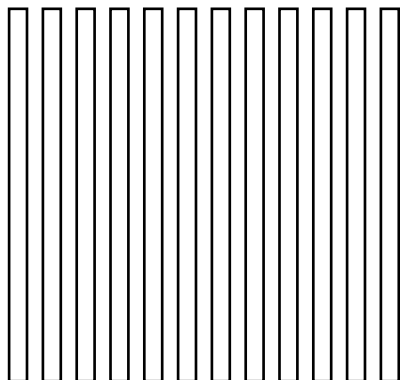

d. 3- 31" horizontal pieces

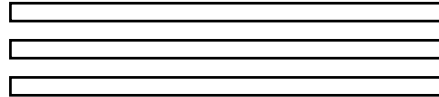

e. 6 - 42" horizontal pieces

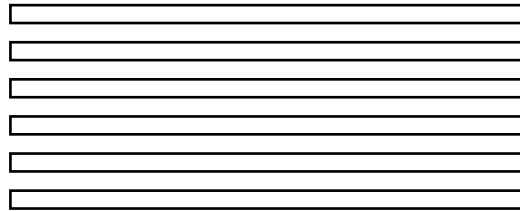

f. 4 - 2" nipples g. 2 - 1" nipples

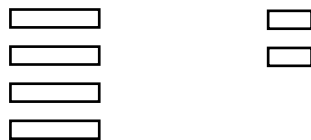

Slightly more than 60 feet of pvc are required, so when you've finished you will have some extra. Buying 7 - 10 foot lengths will cost **\$7.21** plus tax at Home Depot - or slightly more if you want to support your local Hardware store, which I highly encourage you to do.

These are the things you will need aside from the PVC. If you don't already have them you probably should get them because they'll always come in handy, but hey if you have to borrow them or whatever... You need them okay?

Tape Measure



Felt Tip Pen



Any saw that will cut PVC



or



Glue





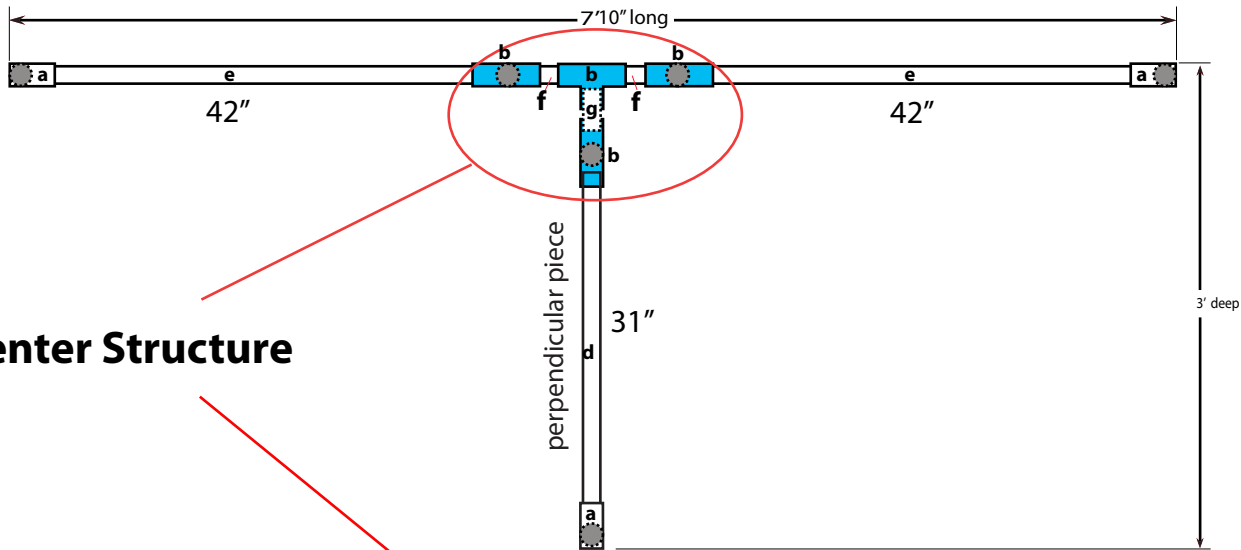



Top and Bottom View - Streetart Display Stand with Perpendicular piece inserted into the center piece



Center Structure

Key

-  or  = "T" pointing away from you
-  or  = "T" on edge - pointing to you
-  or  = "T" pointing to you
-  = "Elbow" pointing away from you

Front View - Street-art Display Stand *without* perpendicular piece inserted into the Center Structure

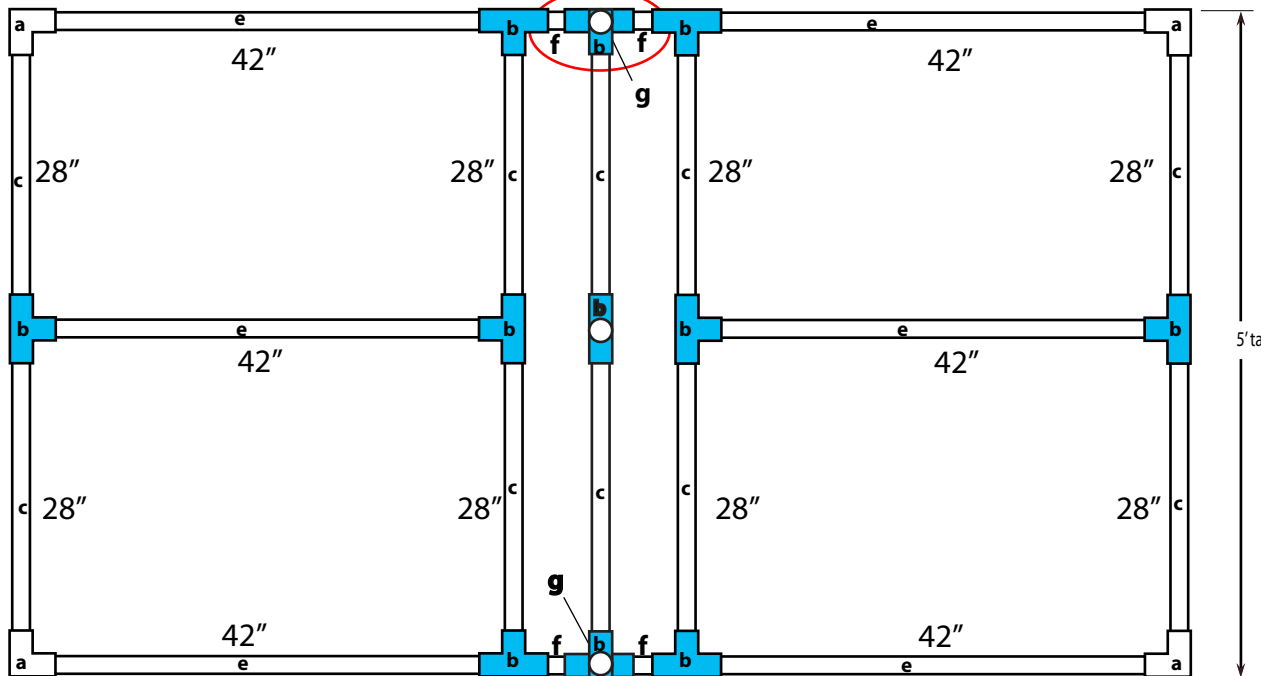

- All 1/2 inch PVC**
- a.** 6 - 90 degree elbows
 - b.** 14 - T's
 - c.** 12 - 28" upright pieces
 - d.** 3 - 31" horizontal pieces
 - e.** 6 - 42" horizontal pieces
 - f.** 4 - 2" nipples
 - g.** 2 - 1" nipples

- All 1/2 inch PVC**
- a. 6 - 90 degree elbows**
 - b. 15 - T's**
 - c. 12 - 28" upright pieces**
 - d. 3- 31" horizontal pieces**
 - e. 6 - 42" horizontal pieces**
 - f. 4 - 2" nipples**
 - g. 2 - 1" nipples**

Acknowledgement

Mr. Robert Lederman has written extensively on how to sell your art on the streets of New York City. I am indebted to him and encourage everyone to check out his blog and his contribution to everyone who wants to pursue this avenue of selling art.

The following information has been copy/pasted from
<http://knol.google.com/k/selling-art-on-the-street-the-basics#where>

"Art vending stands must be located at least 20' from a door (10' from the door of an exclusively residential building), 10' from a corner and must not touch or in any way be attached to a fire hydrant or other item of street furniture such as a parking meter, sign, lightpole or telephone booth. There is no required distance from a fire hydrant, only that you may not touch it (See hydrant laws in FILES section).

*The size limit of an art vending display is **5' in height, 8' in length and 3' in width.** There is no specified limit for a display of art that is not offered for sale. The sidewalk must be at least 12' wide in order to use it. You cannot legally place art against a wall, on a store window or on a fence unless you have written permission from the property owner. You cannot legally lay art on the floor or display it on your car. While you can legally sell another person's art, one person cannot sell from more than one stand unless the total size of the combined stands is 8' or less.*

Individuals selling from two or three full-sized stands or from a grossly oversized stand are both violating the law and unfairly denying other artists and vendors space on the street."

Attached to Center Structure

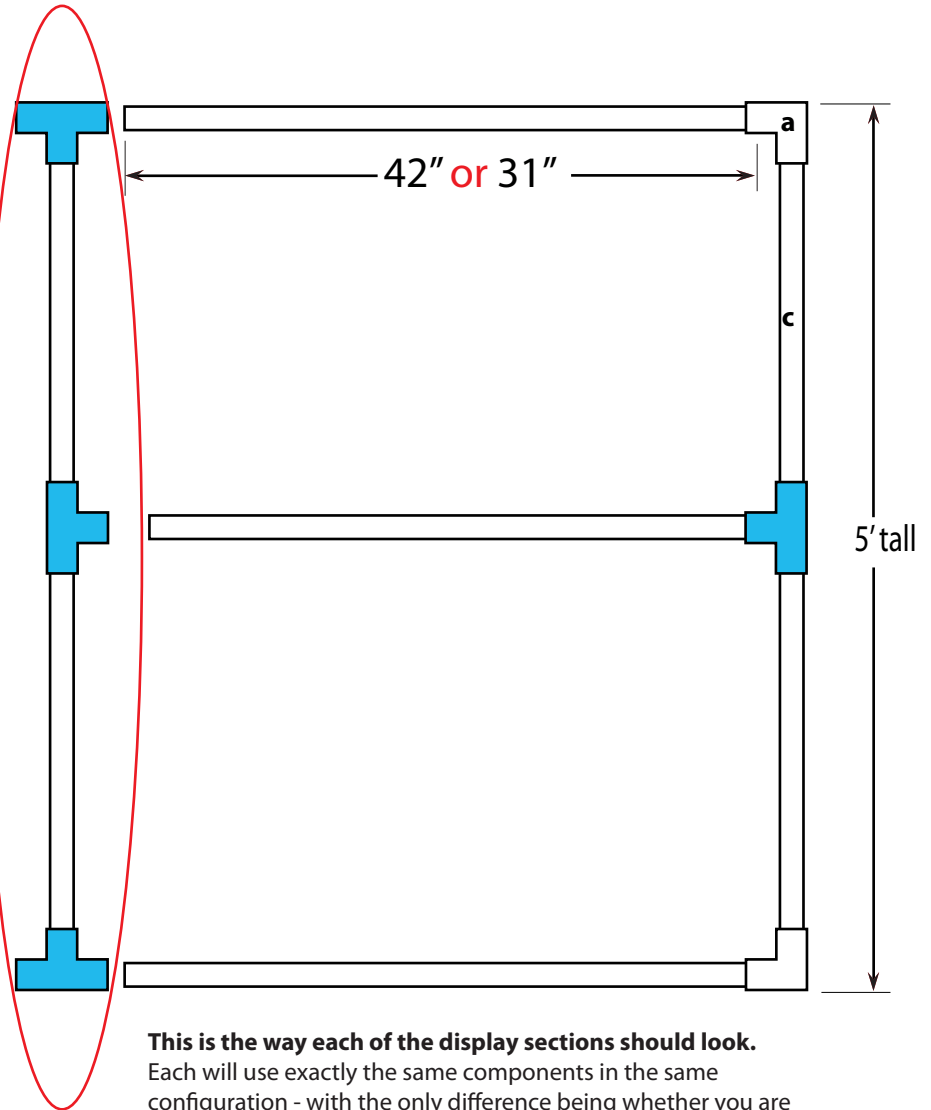

This is the way each of the display sections should look.

Each will use exactly the same components in the same configuration - with the only difference being whether you are making a side "wing" using 42 inch horizontal pieces, or if you are making the perpendicular center which requires the 31 inch horizontal pieces.

Step by Step

1. Measure and mark everything first



2. Then get out your handy saw



or



and make your cuts

c. 12 - 28" upright pieces

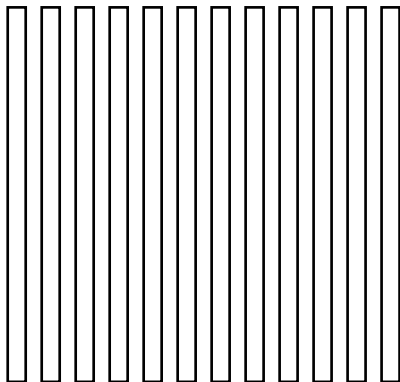

d. 3 - 31" horizontal pieces

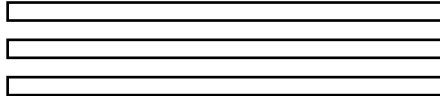

e. 6 - 42" horizontal pieces

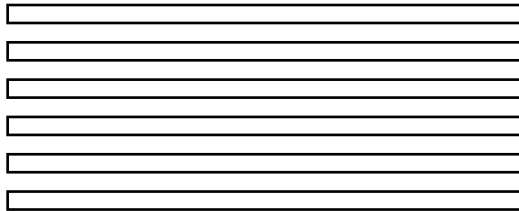

f. 4 - 2" nipples



g. 2 - 1" nipples



3. Six of your upright pieces are ready to use - just set them aside.

Here's where you get to start using the glue. Happy now?:)



4. The other six upright pieces are going to be a part of your Center Structure. They each get a T glued onto one end, and another T placed but not glued onto the other end.

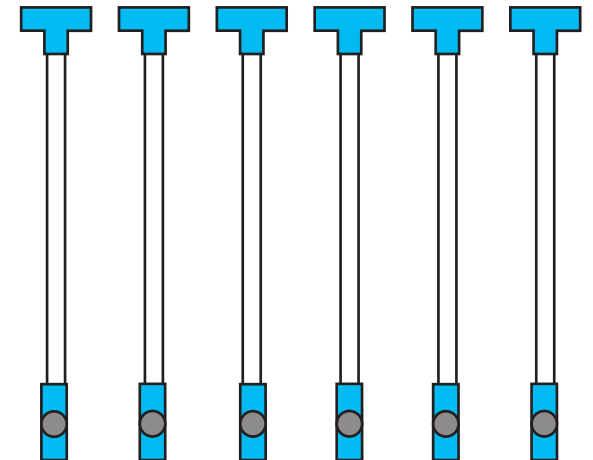

No glue on this end

Step by Step

continued

5. Onto the 31" horizontal pieces attach and glue two of the Elbows and one T

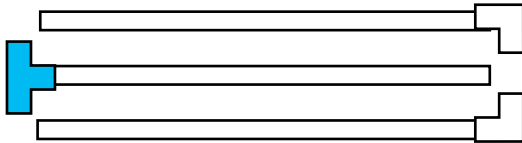

Now is the time to begin thinking of the three horizontal pieces above as a set (that will form your perpendicular front piece), and the two other sets (below) as your wings that will be on either side of the Center Structure.

6. So onto each of the two sets (three pieces) of the 42" horizontal pieces attach and glue two of the Elbows and one T

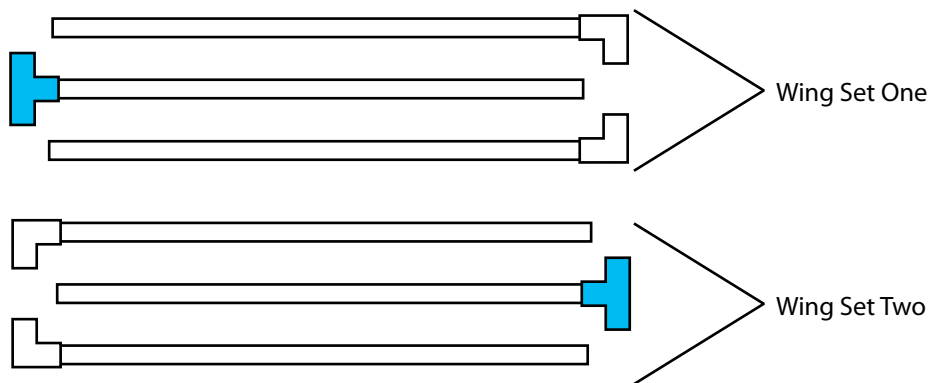

7. Assemble the Center Structure

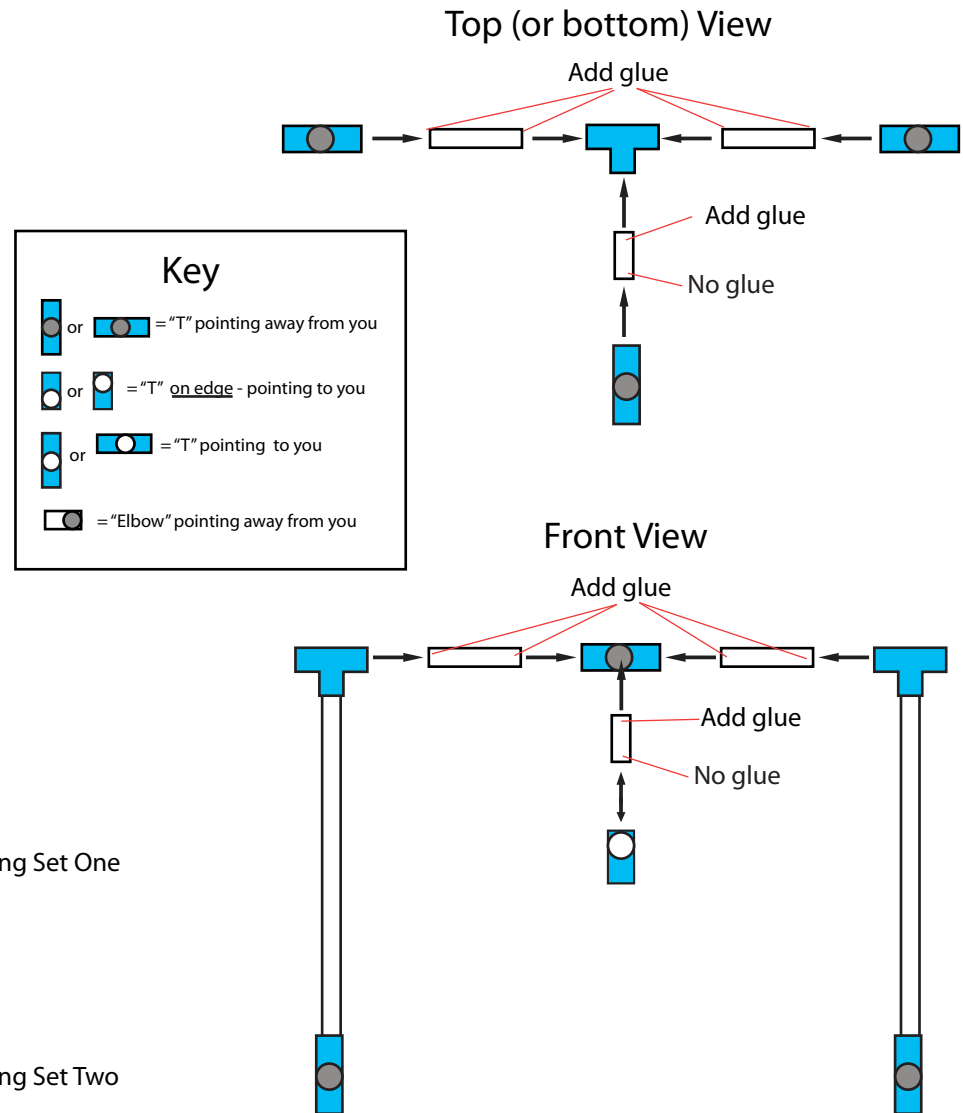

Step by Step

continued

7. Assemble the Center Structure

Top (or bottom) View

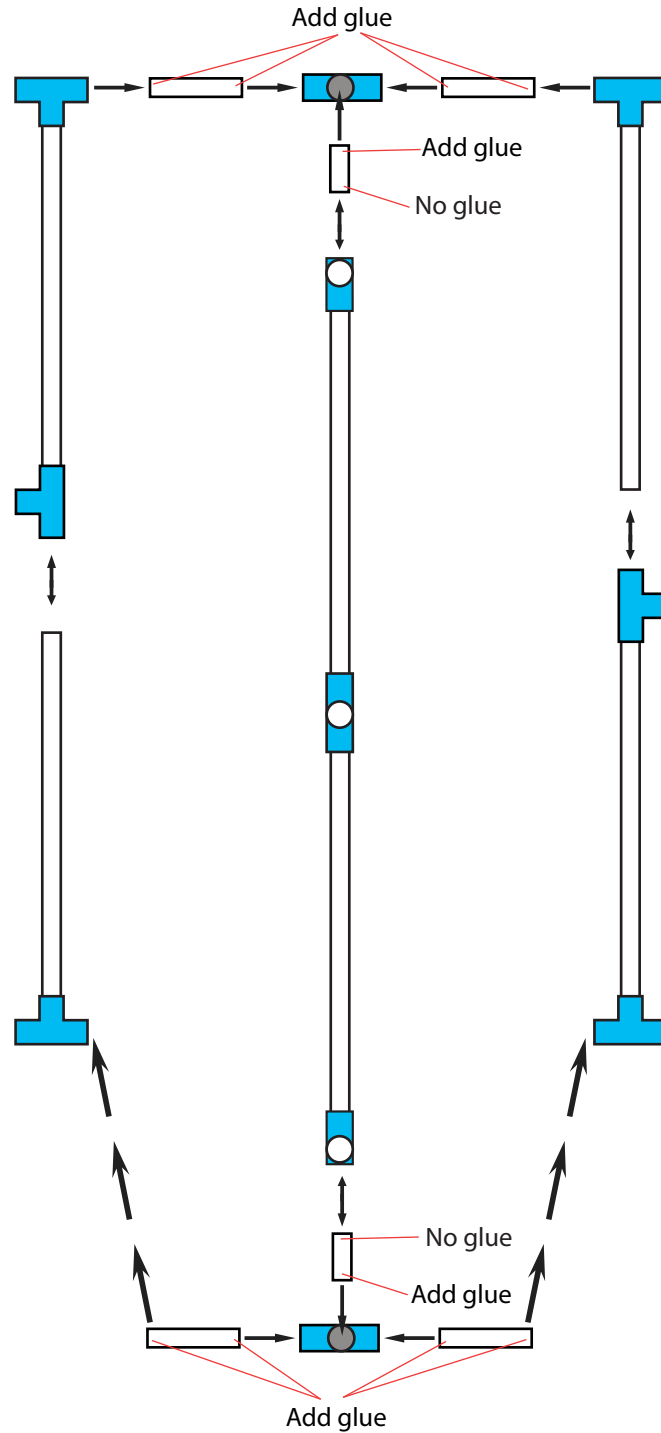
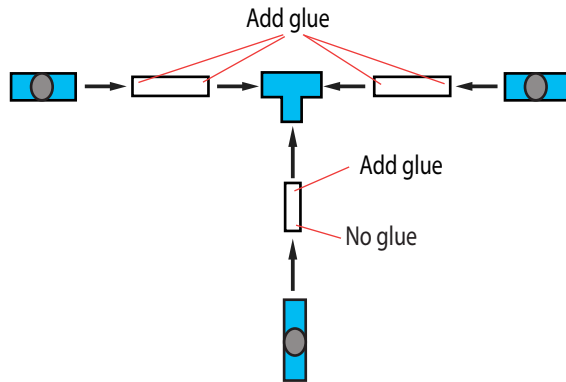

Key

- or = "T" pointing away from you
- or = "T" on edge - pointing to you
- or = "T" pointing to you
- = "Elbow" pointing away from you

Step by Step continued

7. Assemble the Center Structure

Top (or bottom) View

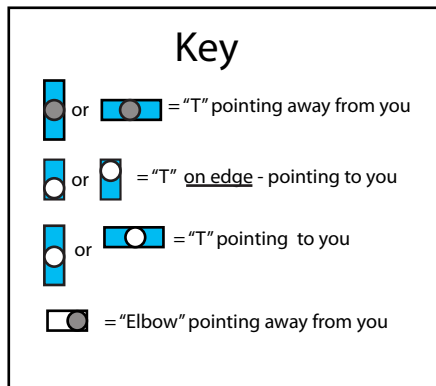
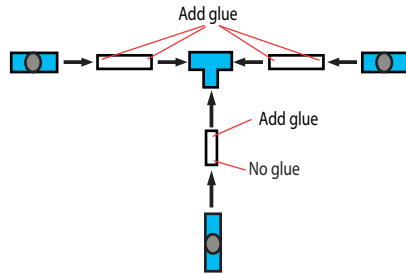

Front View before assembly

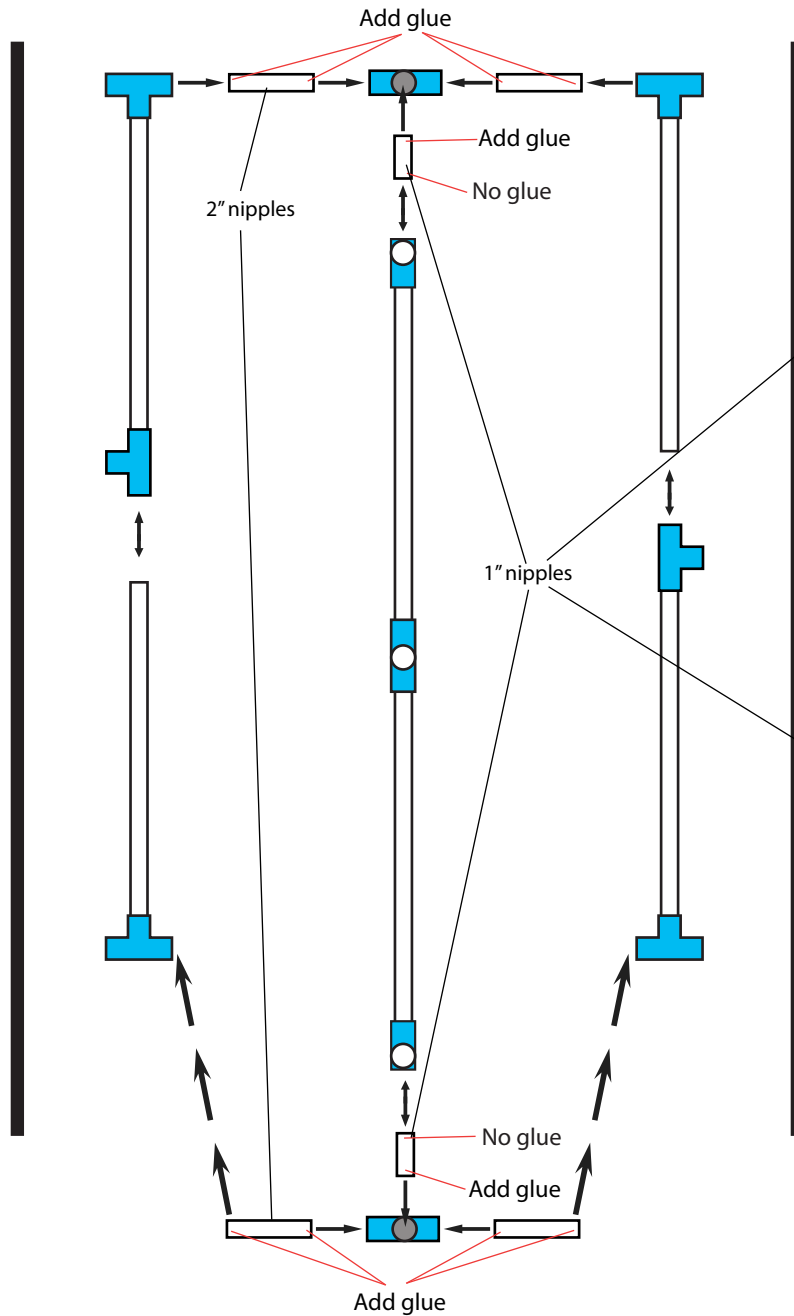

Center Structure Assembled

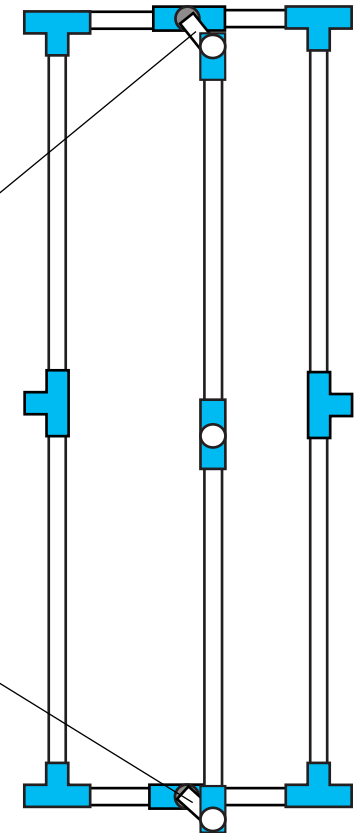





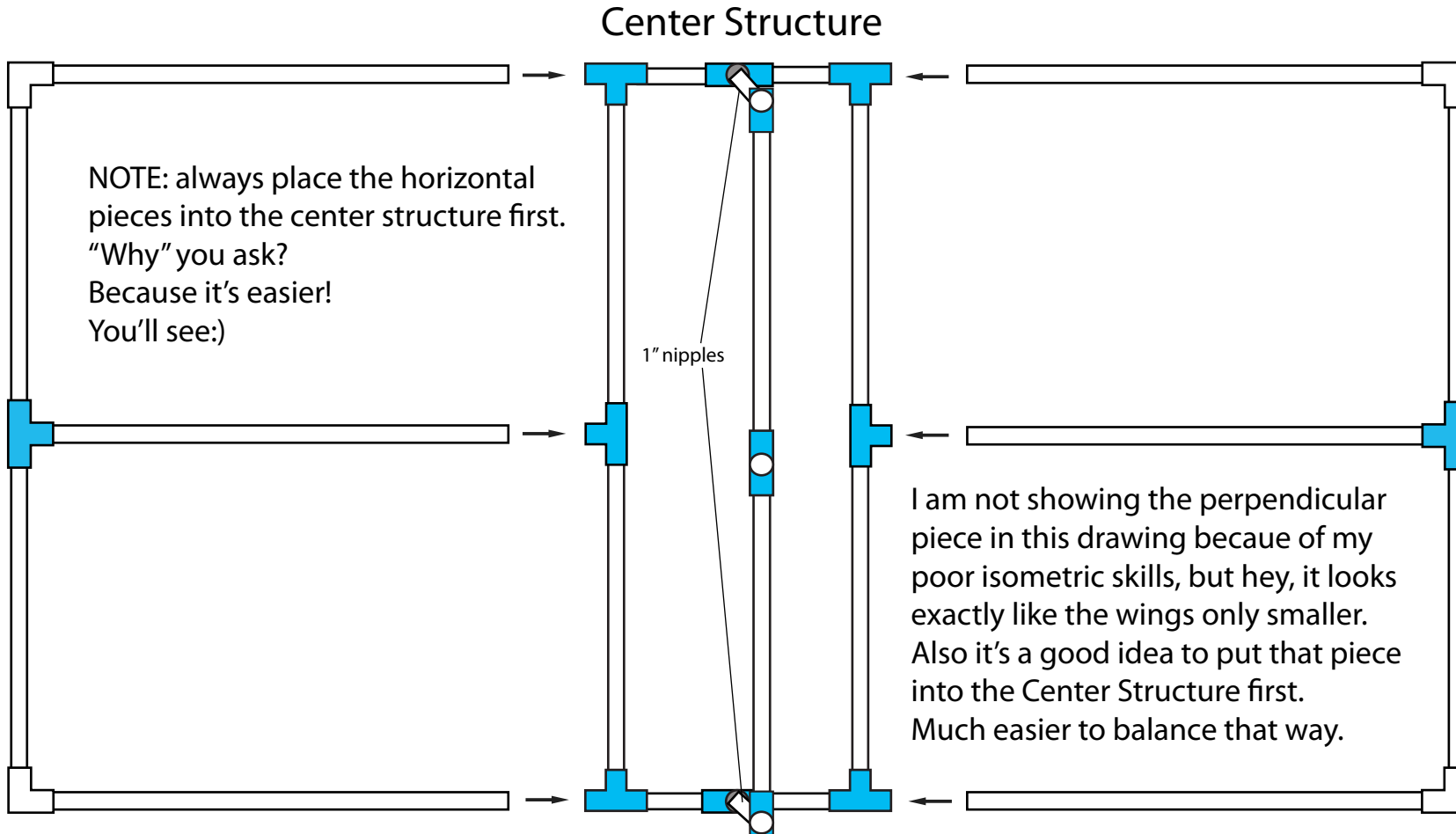
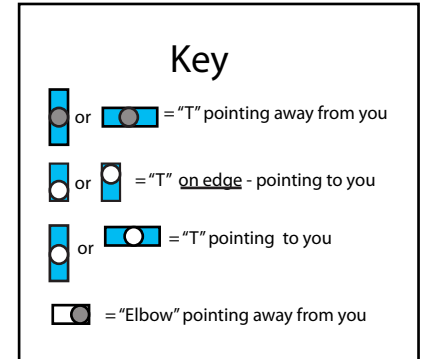

Step by Step continued

8. Place the wings and perpendicular piece into the Center Structure.



Center Structure Top or Bottom View (exactly the same for both)

Key

-  or  = "T" pointing away from you
-  or  = "T" on edge - pointing to you
-  or  = "T" pointing to you
-  = "Elbow" pointing away from you

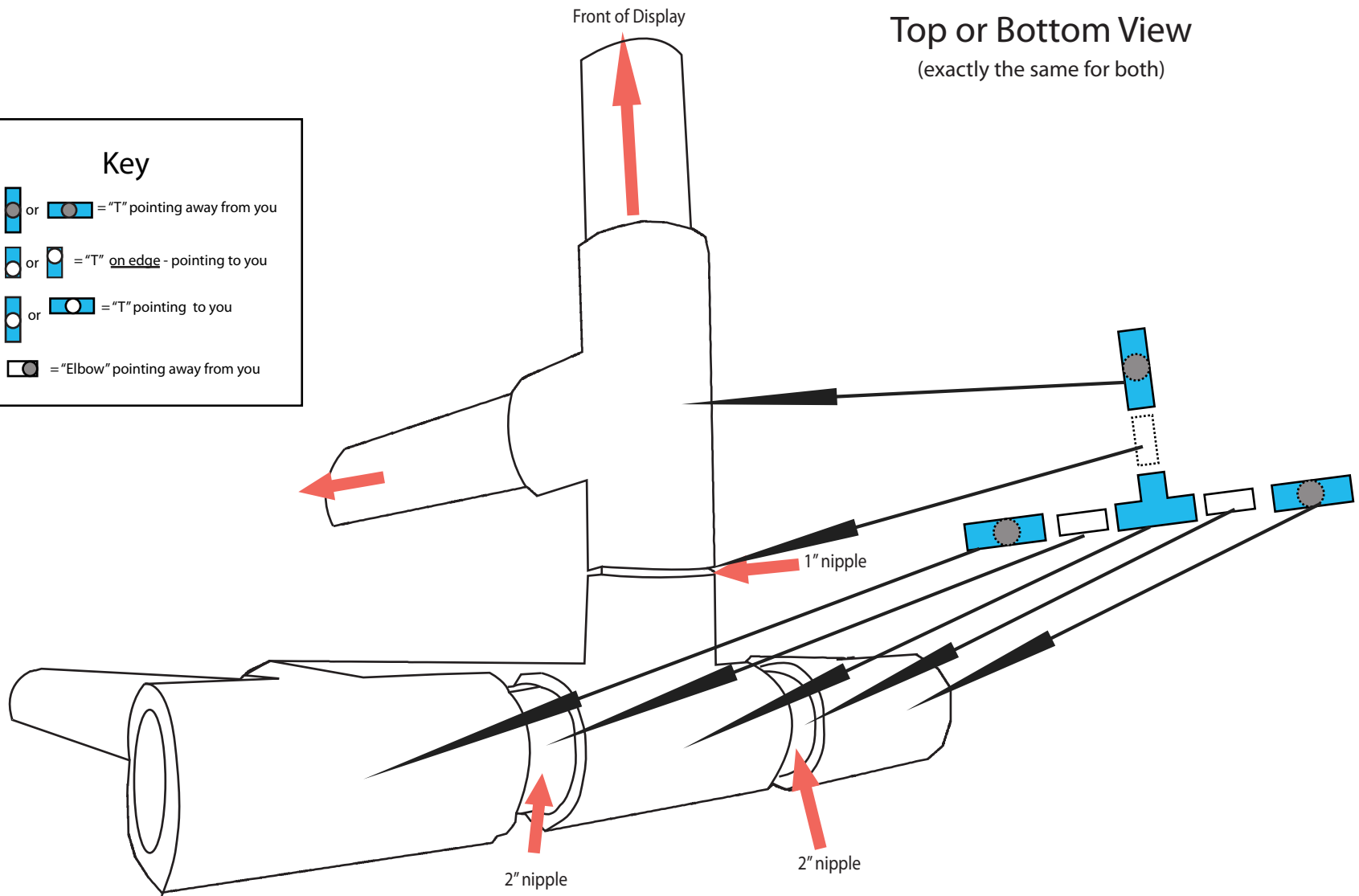

Assembled Streetart Display Stand

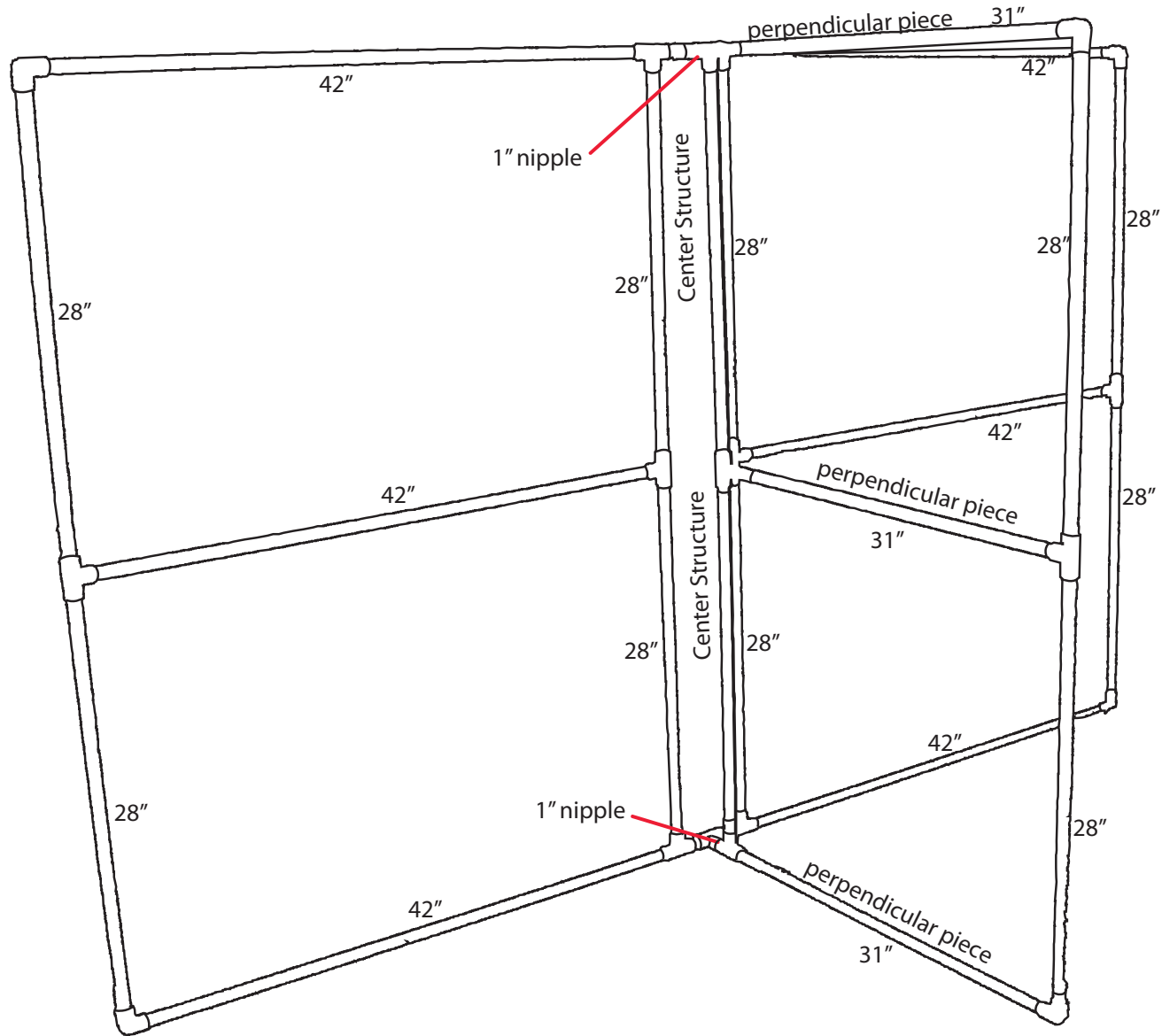

Center Structure

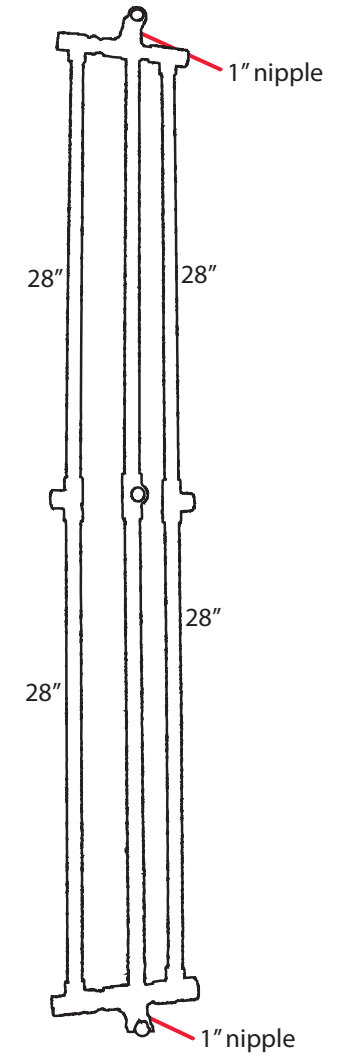

Ta - da!

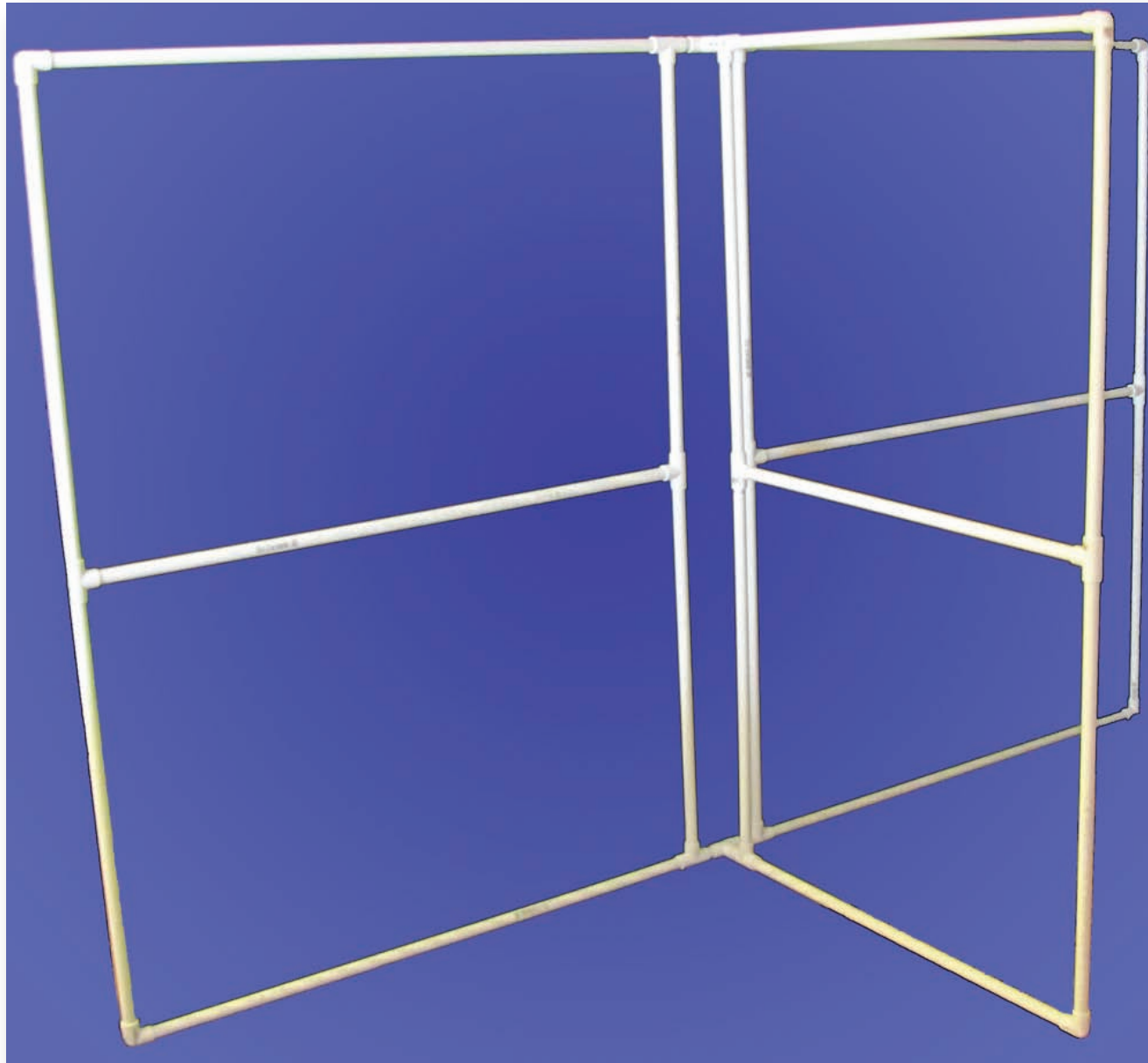

That's it. If I can be of further help please let me know and I will do everything possible to assist you in having this work for you.

Oh there is one thing that you might want to think about and that is: because the stand is so light weight it's a good idea to bring along a couple of been bags to weight it down.

Have fun,

Jon Ellis

Jonathan Ellis
jon@ltbprod.com

*Street-Art Display Stand
Jonathan Ellis
February 1, 2010
All Materials
© copyright 2010 Jon Ellis*